



DIGITAL MICRO VICKERS HARDNESS TESTER

- *VALUE*
- *VERSATILITY*
- *PERFORMANCE*



Equipped with built-in printer and RS232 port; standard machine come with Precision screw rod lifting system all available (precision Worm gear rod lifting system for optional purchase)

BMVH-1000DM/DA



FEATURES: -

- One-time casting aluminum machine body with car painting technology, structure more stable and appearance more decent.
- Digital 10X eyepiece with inbuilt encoder, click the encoder machine will automatic get indentation diagonal length data D1 & D2, no need manual input data into machine, greatly improved testing accuracy and working efficiency.
- With LCD screen digital display, directly display hardness value, dwell time, conversion hardness value, etc.
- Menu structure interface, easy operation.

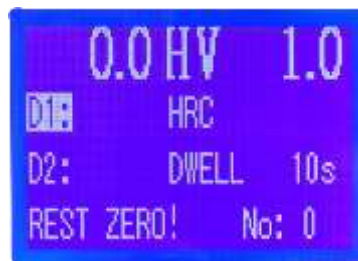

- With HV / HK test function (if need HK test function, optional purchase Knoop diamond indenter and standard Knoop hardness blocks).
- With built-in printer, test result can be printed out directly.
- With RS232 communication port, purchase our data transfer software via RS232 port can save test data to computer and by software can control machine (for Automatic turret machine)
- Double optical path design. Both eyepiece and CCD camera path can work at same time. No need switch optical path. Camera can be install inside machine (camera for optional purchase).

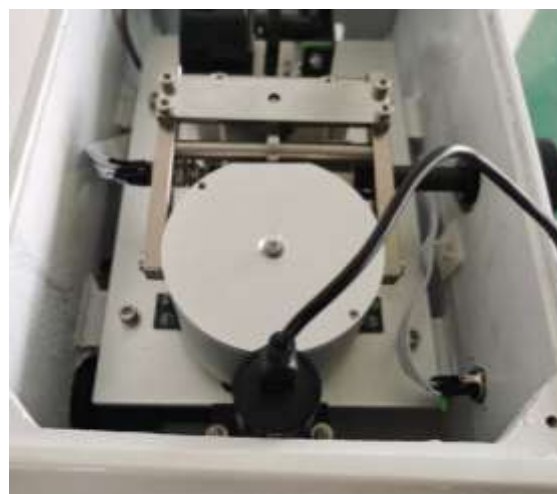
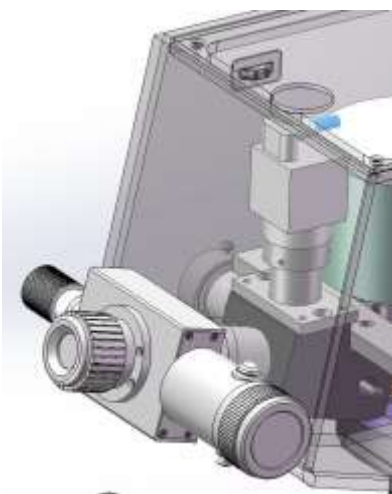

**TECHNICAL SPECIFICATIONS: -**

Model No.	BMVH-1000DM	BMVH-1000DA
Turret	Manual turret	Automatic turret
Test force	10gf (0.098N), 25gf (0.245N), 50gf (0.49N), 100gf (0.98N), 200gf (1.96N), 300gf (2.94N), 500gf(4.9N), 1kgf (9.8N)	
Hardness scale	HV0.01, HV0.025, HV0.05, HV0.1, HV0.2, HV0.3, HV0.5, HV1	
Conversion Scale	HRA, HRB, HRC, HRD, HRF, HV, HK, HBW, HR15N, HR30N, HR45N, HR15T, HR30T, HR45T	
Hardness range	5-3000HV	
Min measuring unit	0.01µm	
Data display	LCD screen	
Data output	built-in printer, RS-232 port	
Maximum height allowed for testing	90mm	
Throat depth	95mm	
X-Y Testing table	Dimension: 100x100mm Max movement: 25x25mm	
Force loading type	Automatic (Loading, Dwell, Unloading)	
Magnification	Eyepiece: 10X; Objective: 10X (observation use); 40X (measuring use) Total: 100X (observation); 400X (Measuring)	
Duration time	1~99s	
Power supply	AC220V±5%, 50-60Hz	
Machine size	405*290*480mm; Net weight: 40kg	
Package size	530x350x820mm; Gross weight: 59kg	



**STANDARD ACCESSORIES: -**

Part Name	Q'ty	Part Name	Q'ty
Weight shaft	1	Weights	6
X-Y Cross clamping testing table	1	Flat clamping testing table	1
Filament clamping testing table	1	Thin Specimen Testing Table	1
Printer paper	1	Level adjustment screw	4
Gradienter	1	Objective 10X, 40X	1+1
Micro Vickers hardness block	2	Eyepiece 10X	1
Dust-proof cover	1	Screw driver	2
Power cable	1	Fuse (2A)	2
Manual	1	Product Certificate	1

FEATURES: -

Precision digital eyepiece (10X) with inbuilt encoder, automatic calculate



LED Cold light source (can be continuous use for 24 hours, no heat generates ensure stable working, servicing life can reach 100,000 hours); Lightness can be adjusted, avoid visual fatigue of operator.

X-Y Testing table of Micro Vickers hardness tester
Dim.:100×100 mm, Max. Travel Range: 25×25mm,
Moving Resolution Ratio: 0.01mm





HVS-A Micro / Vickers Hardness Measurement Software (Optional Purchase 1)

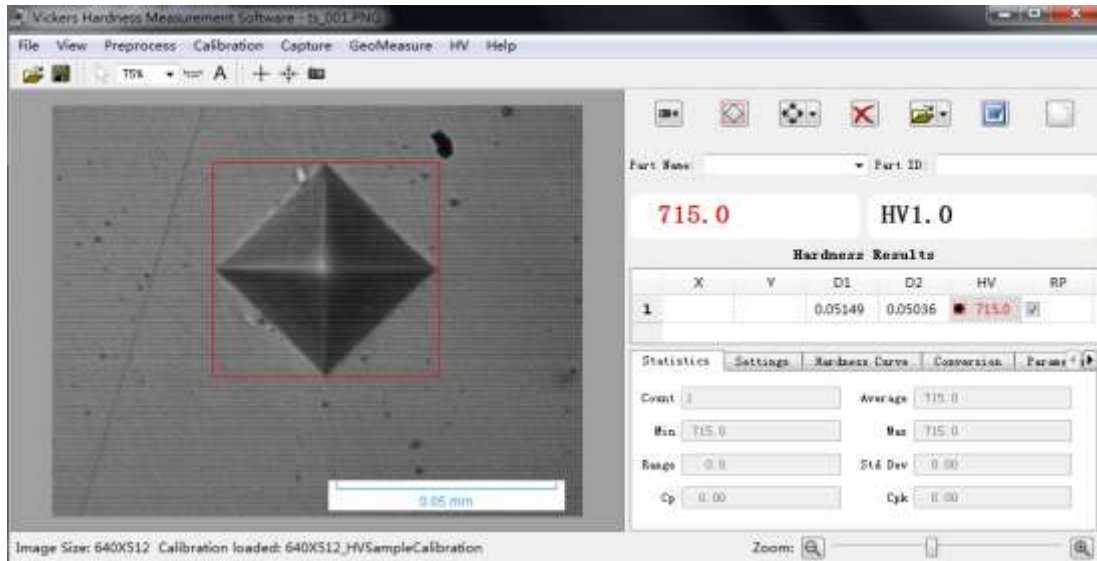

Software support automatic measurement & manual measurement, can generate test report automatically in word / Excel format, including hardness value, test force, indentation image and hardness curve, etc.

Data Transfer Software (Optional Purchase 2)

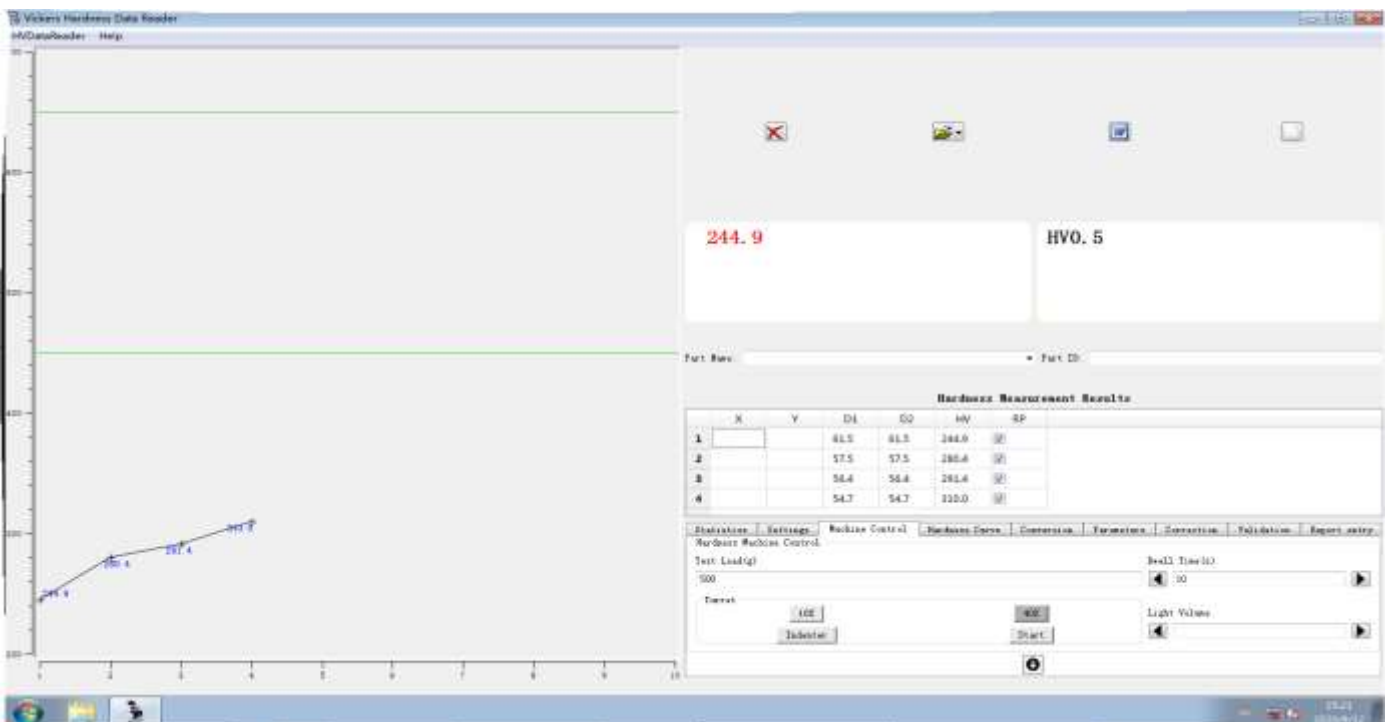

Software can control the machine turret and generate test report including hardness value curve. Software install on the computer, connect with hardness tester through RS232 port. All the testing result can save to computer and generate test report in word format.